

### INSTRUCTION MANUAL

#### Safety Warnings

**This is a Class 1 product and must be earthed.**

- Please read these instructions carefully before commencing any work, and retain for reference.
- This product is only suitable for connection to a 220-240v~50Hz supply and is for outdoor use.
- Install in accordance with IEE Wiring regulations and current Building Regulations.
- To prevent electrocution switch off at mains supply before installing or maintaining this fitting. Ensure other persons cannot restore the electrical supply without your knowledge. If you are in any doubt, please consult a qualified electrician.
- This light fitting should be connected to a fused circuit.
- When changing a bulb, always switch off at the mains and allow the old bulb to cool before handling. Dispose of used bulbs carefully and responsibly. Do not exceed the wattage stated or use a different shape bulb as indicated on the fitting. This product is not suitable for dimming.
- Waste electrical products should not be disposed of with household waste. Please recycle where facilities exist. Check with your local authority or retailer for recycling advice.

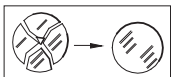

This product is rated at IP44. It is not suitable for location in or near a marine or sea environment. The shade must be replaced immediately should it become cracked or damaged. This fitting must not be used without the shade in place.

#### Care Information

Clean using a soft, dry cloth.

Do not use solvents or abrasive cleaners, as these could damage the finish. **Do not clean the units with a pressure washer.**

#### Assembly/ User Instructions

##### Before you start

Check the packaging and make sure that you have all the required parts. Follow each assembly step in order to prevent incorrect assembly. Ensure that the product is fully assembled as illustrated before use.

##### The Light pack contains:

- Light fitting.
- Terminal connection block(s).
- Fixing pack.

##### The following tools may be required:

- Selection of cross and flat head screwdrivers.
- Electric drill and assorted drill bits.
- Wire strippers.
- Electrical insulation tape.

**These assembly diagrams are intended as a guide – if in doubt consult a qualified electrician.**

##### Layout

- Plan the desired layout of this fitting carefully, ensuring the cables will reach the distance between the junction box and the light fitting.
- This product is designed for domestic and light industrial use. It should not be used to support other objects or used as a replacement for concrete or metal pillars
- Avoid locating any cables in positions that would cause a hazard. Position cables and outdoor rated junction boxes (not supplied) away from areas where they may be at risk from being cut, trapped or damaged.
- We recommend that you use H05RN-F specification cable (not supplied) which is an outdoor grade, rubber sheathed cable. The mains supply cable must have a minimum cross sectional area of 1.0mm<sup>2</sup>
- Cables must be protected using suitable conduit or plastic trunking.

# Assembly/ User Instructions Continued

## Installation

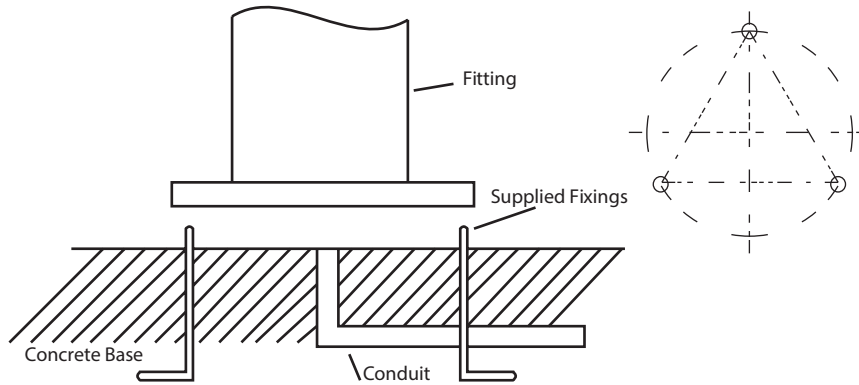

Existing fittings must be completely removed before installation of a new product. Before removing the existing fitting, **carefully note the position of each set of wires**.

- The product must be mounted onto a concrete base or paving slab. It should not be directly installed in the soil.
- Position the supplied right angle J bolts as shown in the diagram. Use the base of the unit for alignment.
- Position the conduit or plastic trunking so that the cable comes up that the centre point of the bollard. Ensure that the cables do not snag.
- Double check that the fixings line up with the holes in the base of the fitting before concreting into position, and allow to set.

## Wiring

Having correctly identified the wiring from your existing light fitting, pull the wire through the hole and connect to the connection block inside the product in the following way:

- Pull terminal block from inside of tube.
- Unscrew the 4 screws which attach the black box to the spacing strip. Open the black box and pull out the terminal block.
- Connect the input wires according to the diagram
- Push terminal block back into the black box. Re-attach the black box to the mounting bracket.

### Check that...

- You have correctly identified the wires.
- The connections are tight.
- No loose strands have been left out of the connection block.

## Commissioning

- Replace the plastic cover and stainless steel plate ensuring that the screws are securely tightened.
- Replace fuse or circuit breaker and switch on. Your light is now ready for use.

## Fitting/replacing bulb

- When changing a bulb, always switch off at the mains and allow the bulb to cool before handling. Dispose of used bulbs carefully.
- Do not exceed the wattage stated or use a different shape bulb from that indicated on the fitting.

