

Wiring

This product is Class I product must be earthed. They must be joined together and well insulated with good quality insulation tape. This is to ensure earth continuity throughout your property.

Having correctly identified the wiring from your existing light fitting and connect to the connection block inside the product in the way on the right:

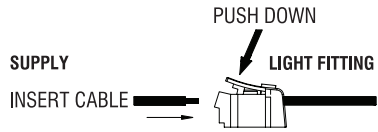

Check that...

- You have correctly identified the wires.
- The connections are tight.
- No loose strands have been left out of the connection block.

Maintained(Unswitched) Wiring: The product on permanently and comes on during a power failure.

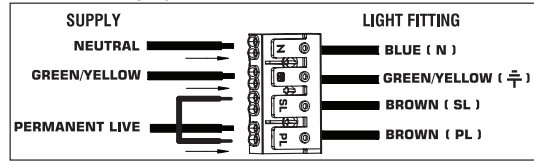

Maintained (Switched) Wiring: The product is used as a normal light - switch on/off, light turns on/off. Comes on during a power failure.

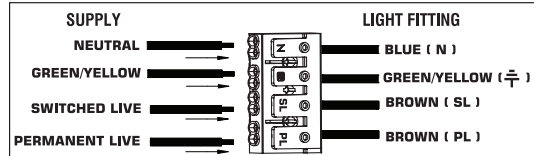

Non-Maintained Wiring: The product is normally off and comes on during a power failure.

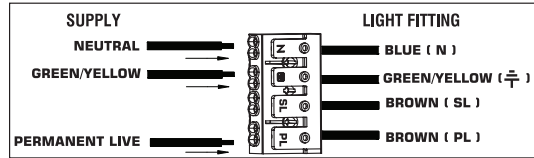

Technical data

Supply Voltage: 220-240 V~, 50 Hz
Bulb Type: 103262 : 30W/19W LED module (SMD) CCT, 3000/4000/6500K
103263 : 50W/24W LED module (SMD) CCT, 3000/4000/6500K
103264 : 57W/35W LED module (SMD) CCT, 3000/4000/6500K
This product contains a light source of energy efficiency class **D**.

 Non-replaceable light source

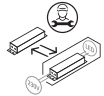

Replaceable control gear by a professional



Conformity with all relevant UKCA Directive requirements.

Conformity with all relevant EC Directive requirements.



Waste electrical products should not be disposed of with household waste. Please recycle where facilities exist. Check with your Local Authority or local store for recycling advice.



This product is Class 1, must be connected to earth.



This product is not suitable for dimming.



This product is rated at IP65.



Caution! Risk of electric shock!

Duration: 3 hours (180 Minutes)
Mains input current: 22mA
input power in mains operation: 2.5W
Emergency power: 1W (Battery)
Battery Specification: LiFePO4 3.2V 1500mAh
Battery Charge Time: 24 Hours
Battery charge current: 200mA
Battery warranty: 5 years
Operating Temperature: 0°C -45°C

Instruction manual

LED Anti-Corrosive Pro Batten EM

103262, 103263, 103264

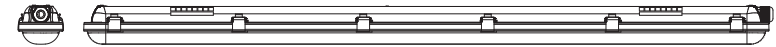

Care and Safety

Live Voltages may be present in this unit even when turned off or when completely disconnected. We recommend cleaning with a soft dry cloth. Do not use solvents or abrasive cleaners as these could damage the finish. For your safety, always switch off the power supply before cleaning.

For further information, please visit <https://www.lighting-info.co.uk/103262>

V4 19/04/2024
UK Manufacturer: BH17 7BY
EU Manufacturer: Brilliant AG,
Brilliantstrasse 1, D-27442 Gnarrenburg

saxby
lighting

www.saxbylighting.com

saxby
lighting

Thank you for purchasing this light fitting. Please read the instructions carefully before use to ensure safe and satisfactory operation of this product. Please retain these instructions for future reference.

Warning

This is a Class 1 product and must be earthed.

Please read these instructions carefully before commencing any work.

This unit must be fitted by a competent and qualified electrician.

Check the pack and make sure you have all the parts listed.

Install in accordance with the IEE Wiring regulations and current Building Regulations.

To prevent electrocution switch off at mains supply before installing or maintaining this fitting. Ensure other persons cannot restore the electrical supply without your knowledge. If you are in any doubt, please consult a qualified electrician.

This light fitting should be connected to a fused circuit.

If replacing an existing fitting, make a careful note of the connections.

Waste electrical products should not be disposed of with household waste. Please recycle where facilities exist. Check with your local authority or retailer for recycling advice.

Layout

Plan the desired layout of these fittings carefully, ensuring the cables will reach the distances between the junction box and the each light fitting.

Avoid locating any cables in positions that would cause a hazard. Position cables and outdoor rated junction boxes (not supplied) away from areas where they may be at risk from being cut, trapped or damaged.

We recommend that you use H05RN-F specification cable (not supplied) which is an outdoor grade, rubber sheathed cable.

The mains supply cable must have a minimum cross section area of 1.0mm².

Cables must be protected using suitable conduit or plastic trunking.

Take care not to drill into any pipes or mains cables beneath the surface during mounting holes preparation.

This product can be installed on the ceiling or wall.

Installation

Existing fittings must be completely removed before installation of a new product. Before removing the existing fitting, carefully note the position of each set of wires.

Note that the switch is turned off before installation.

The mounting surface must be flat and smooth to ensure a good fit.

- Hold the product in place and mark the position of the fixing holes. This may require the help of an assistant. If wall mounting, ensure that the product is level.
- Take care to avoid damaging any concealed wiring and pipes. The correct fixings should be used for brick, cavity walls or plasterboard.
- Ensure the ceiling or wall is capable of holding the weight of the product and then fix brackets in place.
- Open the diffuser cover by unfastening securing clips.
- Feed the supply cable through the end grommet and fix the light fitting into position. Alternatively, the grommet can be removed and the supplied cable gland fitted.
- Connect the supply cable to the quick fit terminal block as detailed wiring diagram.
- Connect the battery output cable to the EM driver.
- Close diffuser cover by clipping it into place.
- Fix two suspension brackets into the position with the installation plugs and screws.
- Fix the light fitting by suspension brackets in place.
- Replace fuse or circuit breaker and switch on. Your light is now ready for use.

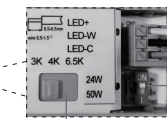
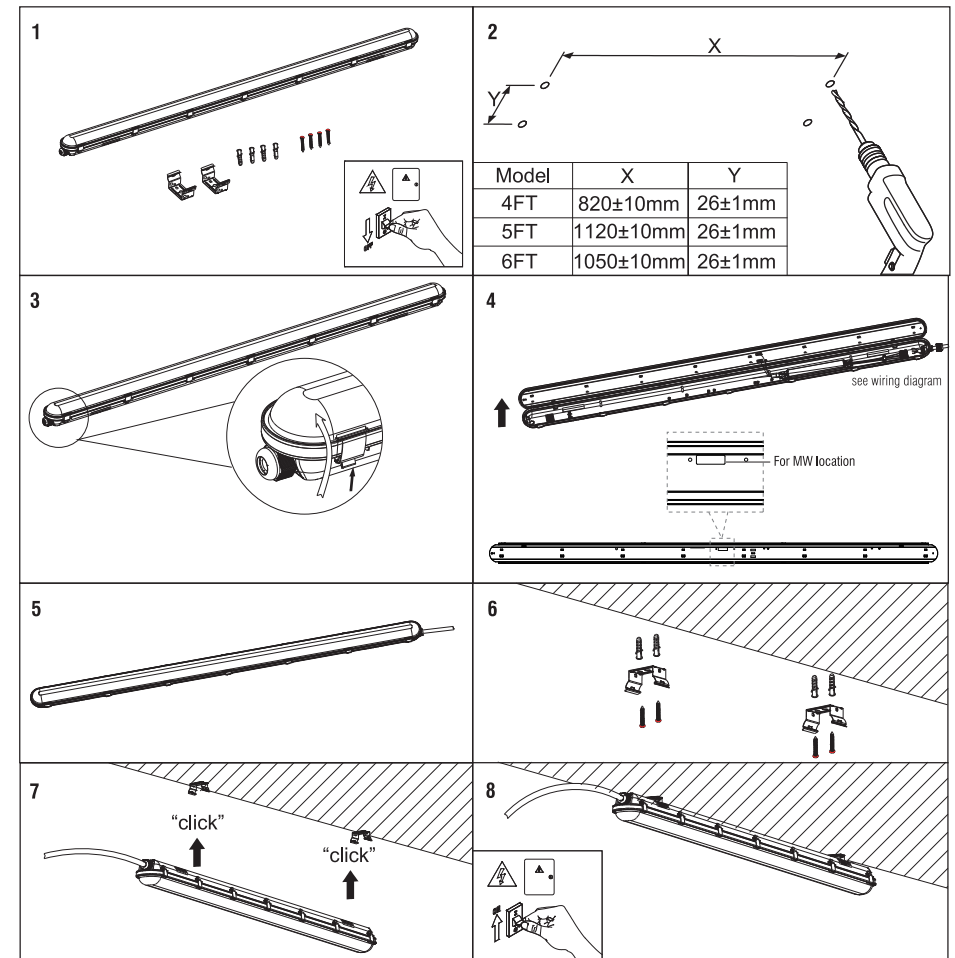

Watt Switch

CCT Switch

The wattage is changeable between the different wattage using the wattage switch on the driver before installation.

- 19W For the 103256 is the 30W/19W selectable.
- 30W Default setting is 30W.
- 24W For the 103257 is the 50W/24W selectable.
- 50W Default setting is 50W.
- 35W For the 103258 is the 57W/35W selectable.
- 57W Default setting is 57W.



The colour is changeable between 3000/4000/6500K using the CCT switch on the driver before installation. Default setting is 4000K.

Choose your preferred wattage and colour before installing by wattage switch or CCT switch on the driver.

Note: Before you change the wattage or colour, please turn off the power for safety.